

Z487/2/...

Mat.: 1.2311 / 1080 N/mm<sup>2</sup>

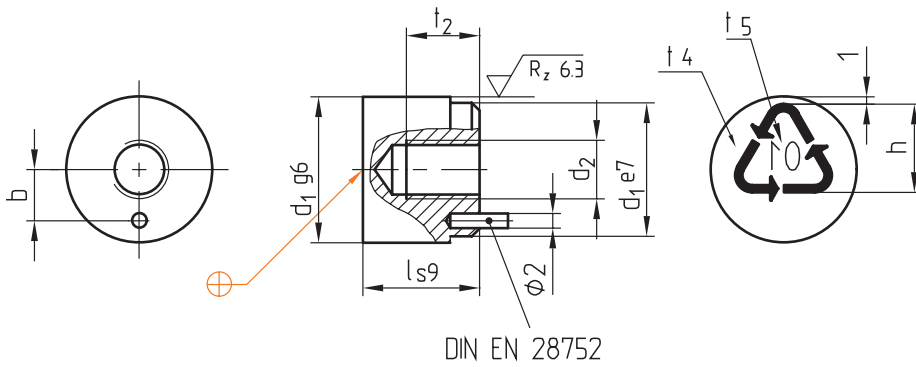

► Info



t<sub>4</sub>, t<sub>5</sub> = Schrifttiefe  
 Depth of characters  
 Profondeur de la gravure

h	t <sub>4</sub>	t <sub>5</sub>	b	t <sub>2</sub>	d <sub>2</sub>	l	Typ	d <sub>1</sub>	Beschriftung / Inscription		Nr./No.
6,9	0,1	0,1	4	6	M4	12	2	12	—	01	Z487/2/12/01
									—	02	02
									—	03	03
									—	04	04
									—	05	05
									—	06	06
9,5	0,12	0,12	5,5	8	M6	16	2	16	—	01	Z487/2/16/01
									—	02	02
									—	03	03
									—	04	04
									—	05	05
									—	06	06
12,5	0,15	0,15	7	10	M8	20	2	20	—	01	Z487/2/20/01
									—	02	02
									—	03	03
									—	04	04
									—	05	05
									—	06	06

This is trial version  
 www.adultpdf.com